



ILLUSTRATED PARTS LIST

CABRIO 243-244

SERIAL NUMBER PREFIX 01

CE

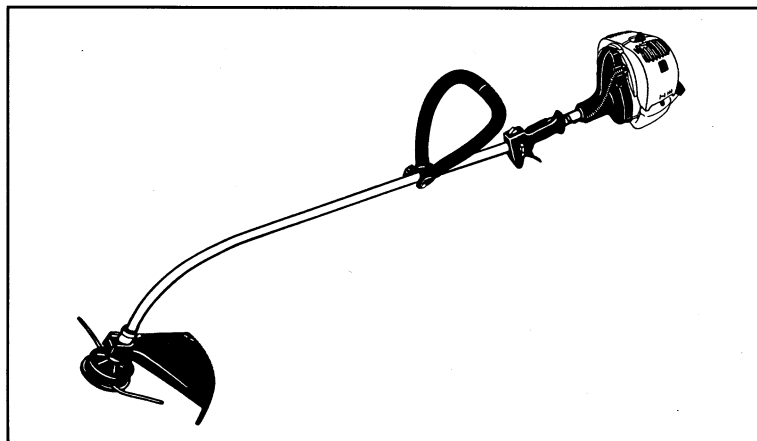

January 2001

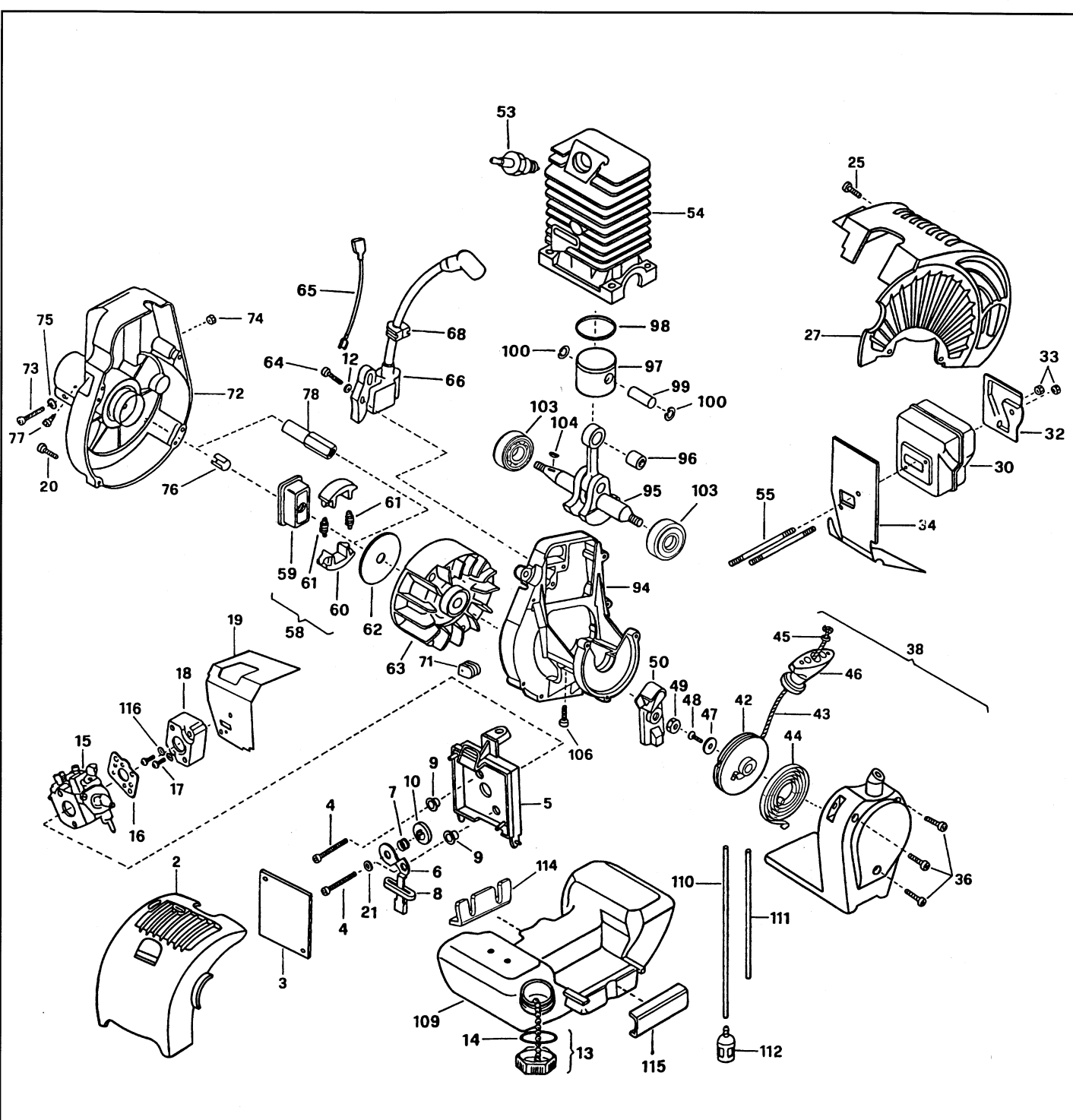

FIGURE 1

B	2	242019	1	B	19	242034	1	47	•	241703	1	68	236322	1	100	•	235008	2			
	3	242035	1		20	227568	M4x20	4	48	•	240862	1	71	241607	1	C	103	242030	2		
	4	235808	M5x50	2	21	235248	1	49	241624	1	C	72	241725	Cabrio 244	1	C	104	227631	1		
	5	248485	1		25	241963	M4x22	2	50	241784	1	C		241977	Cabrio 243	1		106	235803	M5x25	4
	6	•	241769	1	27	242079	1	A	53	92879	1	73	•	235803	1	C	109	242040	1		
	7	•	235822	1	C	30	242131	1	C	54	241800	1	74	•	229524	1	B	110	•	229717	1
	8	•	241622	1		32	323760	1	55	242037	2	75	•	235248	1	B	111	•	229743	1	
	9	•	227022	2		33	235642	2	B	58	241793	1	76	•	228260	Cabrio 244	1	A	112	93720	1
	10	•	241602	1	B	34	242036	1	59	•	241789	1	77	236981	1		114	242038	1		
B	13	236563	1		36	241963	M4x22	3	60	•	241743	2	78	241964	1		115	242039	1		
A	14	•	236564	1	C	38	242041	1	A	61	•	241794	2	94	242029	1		116	235248	2	
C	15	FIGURE 4		B	42	•	241620	1	62	241604	1	C	96	•	235742	1					
A	16	241600	1	A	43	•	241746	1	63	241796	1	C	97	248177	1						
	17	235806	M5x20	2	B	44	•	241619	1	64	235806	M5x20	2	B	98	•	240002	1			
C	18	241750	1		45	•	235612	1	65	241606	1	B	99	•	241735	1					
					46	•	241778	1	C	66	241749	1									

A = high moving - alta rotazione - haute demande - große Nachfrage B = medium moving - media rotazione - moyenne demande - mittelmäßige Nachfrage C = slow moving - bassa rotazione - basse demande - wenige Nachfrage

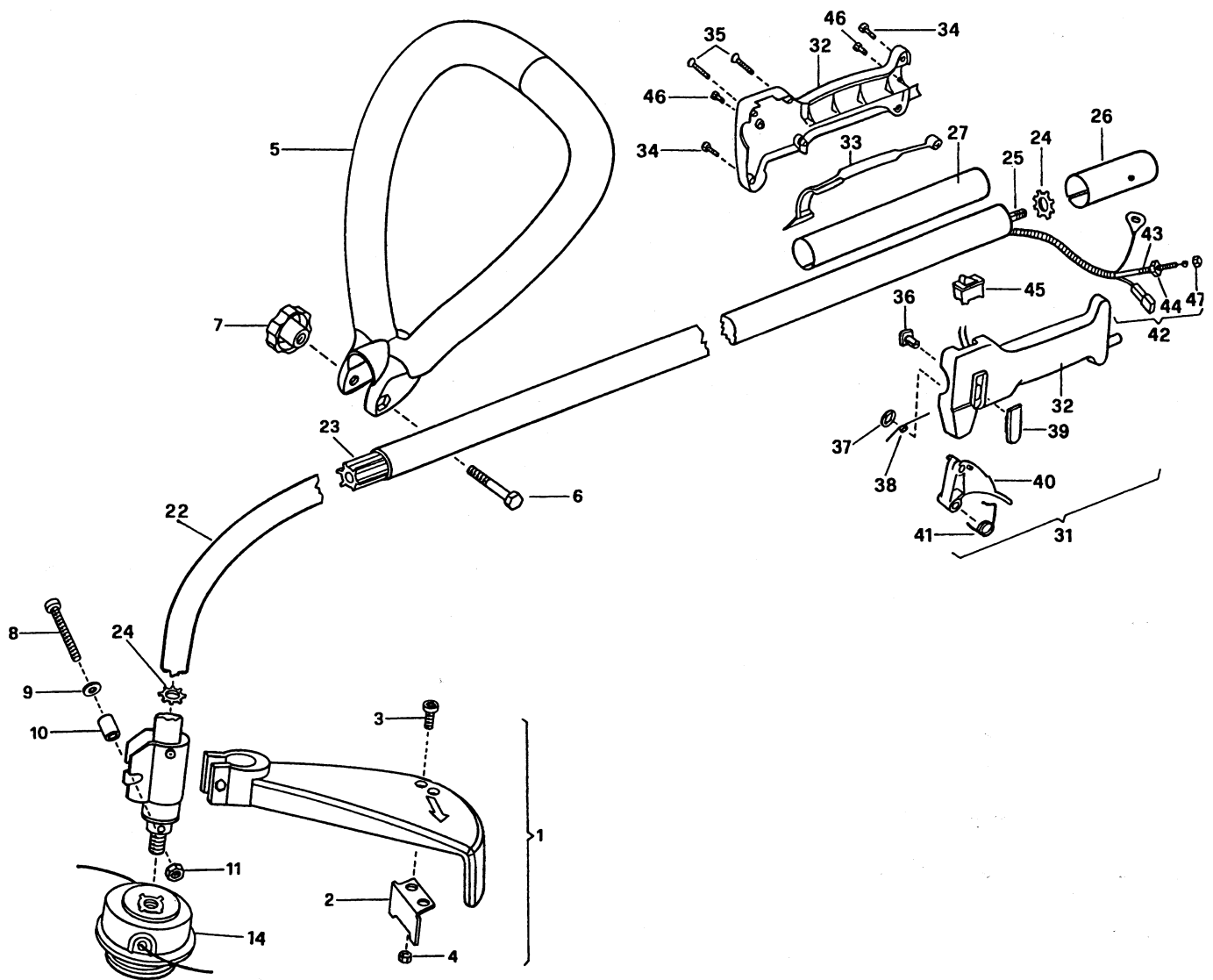

FIGURE 2

B	1	248377	1	26	241838	1	C	45	●●	236394	1	
	2	●	241973	1	27	241727	1	46	●	236981	2	
	3	●	236381	M5x10	2	31	227280	1	47	●	235912	1
	4	●	235642	2	32	●	246955	1				
	5	248574	1	33	●●	229819	1					
	6	●	242146	M6x40	1	34	●	240618	2			
	7	●	242147	1	35	●	240833	4				
	8	228320	M6x45	1	36	●	229823	1				
	9	236936	1	37	●	227065	1					
	10	242061	1	38	●	229973	1					
	11	235912	1	39	●	229824	1					
A	14	FIGURE 3		40	●	241296	1					
	22	241966	1	41	●	240091	1					
	23	●	241968	1	C	42	●	227067	1			
	24	●	241745	2	C	43	●●	227073	1			
C	25	228143	1	44	●●	235912	1					

A = high moving - alta rotazione - haute demande - große Nachfrage

B = medium moving - media rotazione - moyenne demande - mittelmäßige Nachfrage

C = slow moving - bassa rotazione - basse demande - wenige Nachfrage

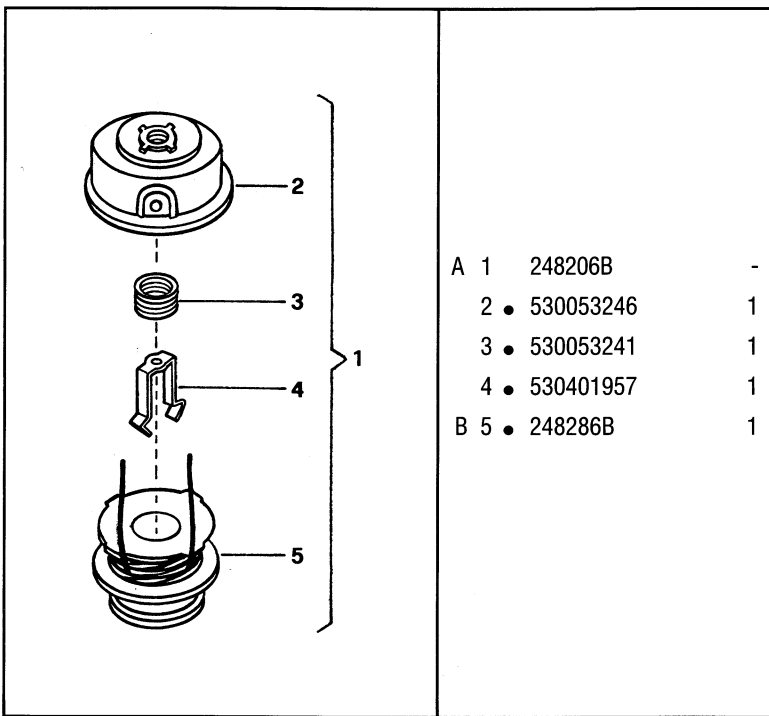

A	1	248206B	-
	2	● 530053246	1
	3	● 530053241	1
	4	● 530401957	1
B	5	● 248286B	1

FIGURE 3

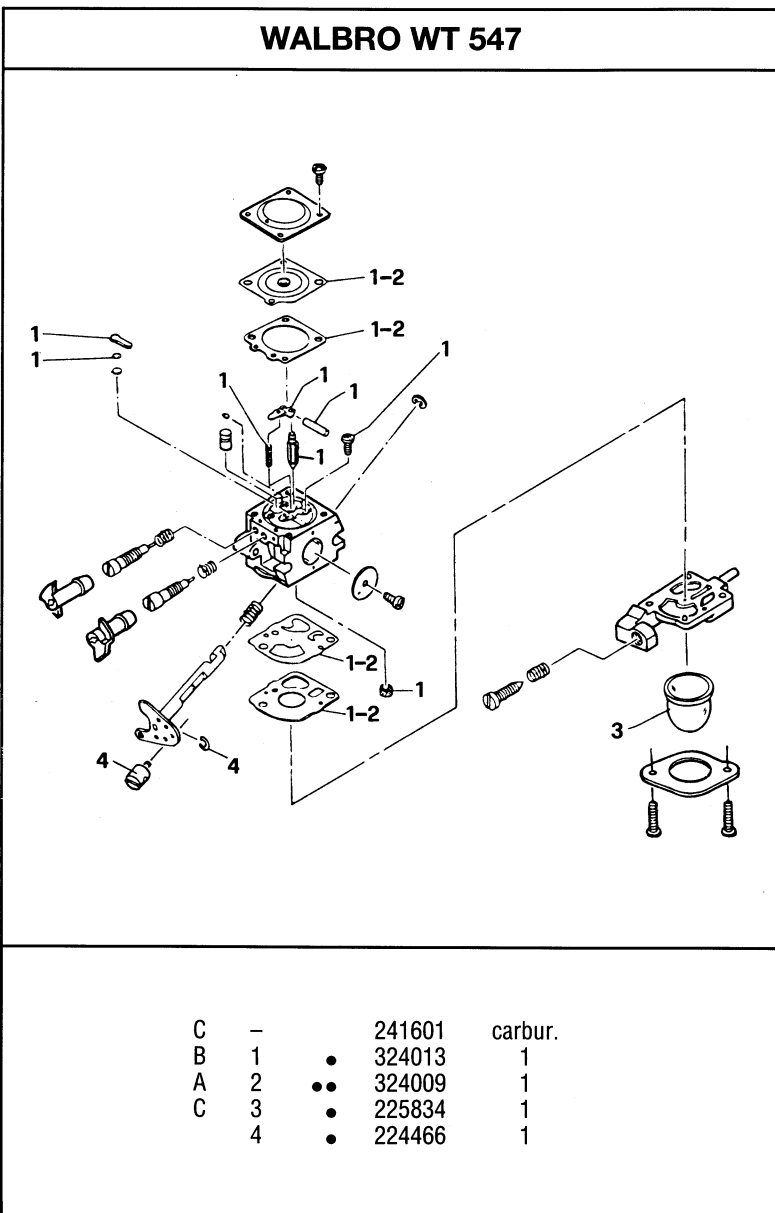

FIGURE 4

A = high moving - alta rotazione - haute demande - große Nachfrage
 B = medium moving - media rotazione - moyenne demande - mittelmäßige Nachfrage
 C = slow moving - bassa rotazione - basse demande - wenige Nachfrage

